

ELECTRONIC FIRE BELL SERIES

Brand new electronic fire alarm with bell sound, emergency whistle, fan-horn sound.

全新開發:和弦擊鈴音、複頻式汽笛音、風雷音等警報器，並以美規、歐規電器蓋板尺寸或同六吋圓鐵盤鈴式之外型結構,供選用裝置場合



• **Lxx-F110** 6" circular bell design

This will replace the traditional metal fire bell with loud-ness and electric characteristics improvements

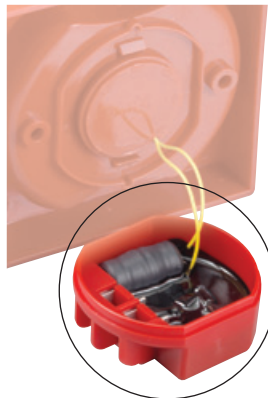

• **Lxx-F99 & Lxx-F110** Inside-view
Filling epoxy for solid-state with excellent damp-proof and highest reliability



• **Lxx-F99**



• **LD-99JB**

A suitable plastic frame **junction box** is available for mounting on the wall when there is no outlet ready to use



• **Lxx-F99 + JB**

The pitches of holes for screwing fits USA outlet size

The pitches of holes for screwing fits European outlet size

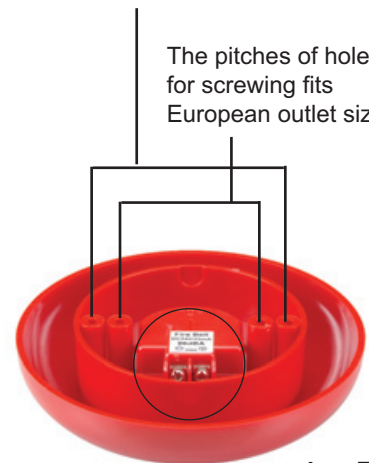

• **Lxx-F110**
Back-view

Screw type terminal block for wire connection



• **Lxx-F99**
Bottom-view

Key Specifications

- Input : 24VDC (12~30V DC)
- Sound output : 100 ± 5 dB
(at 24V DC, 1 M)
- Tone : Bell sound or Sweep Tone
- Operating current : 22mA (Bell only)
(at 24V DC)
- Color : Red
- *Please refer to page 35 for dimensions

Dimensions

Lxx-110 Series

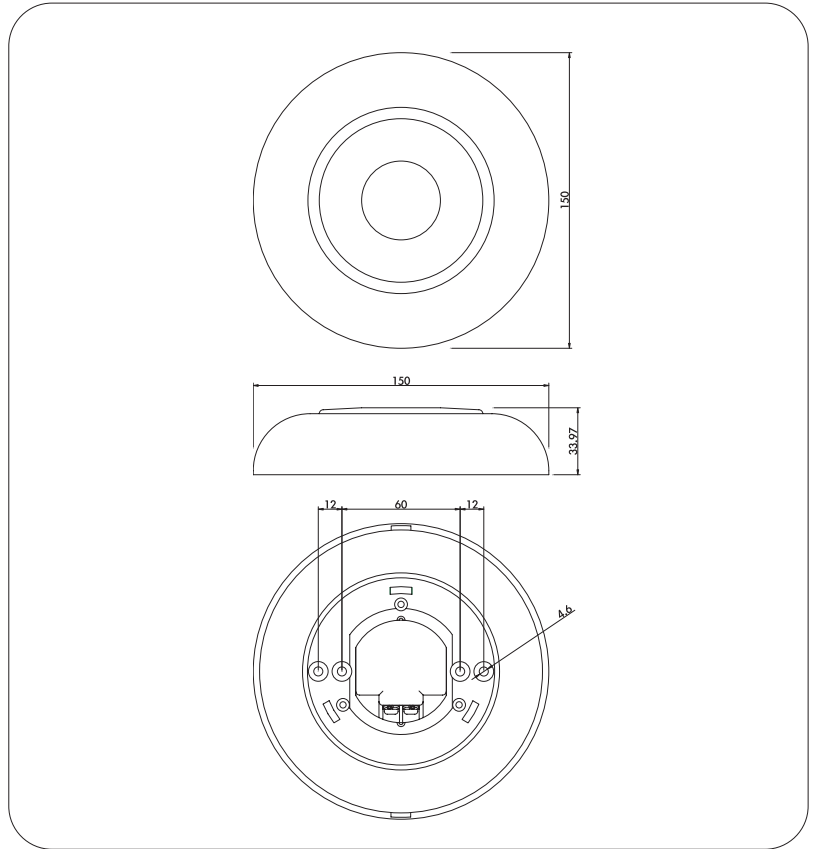

Lxx-99 Series & 99JB

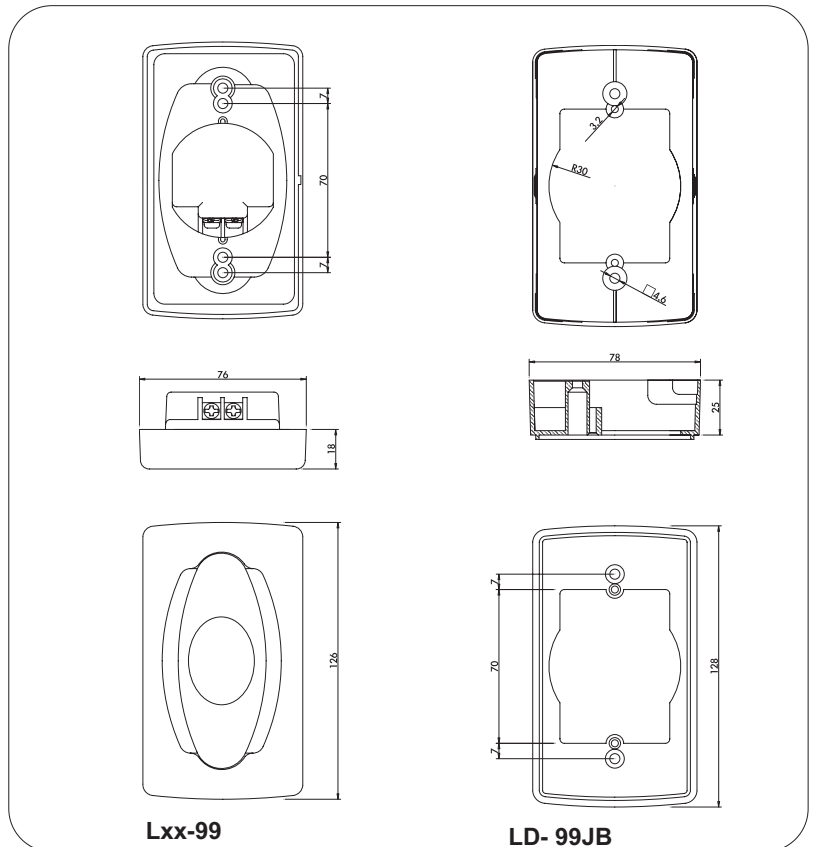

Lxx-99

LD-99JB